

NS 103

ECONOMICAL WATER DISTILLER



NS 103 is designed to produce distilled water economically and rapidly.

Water is heated in the boiling tank by means of stainless steel electrical heater to produce steam and then the steam is condensed while it is passing through special serpentine in which cooling water is circulating and distilled water is produced.

By means of the preheated water in the condenser, boiling duration is reduced and power consumption is decreased.

All surfaces in contact with water and steam are made of stainless material.

The produced distilled water is free from any metallic ions.

Heater is protected against empty boiling tank and water interruptions and there is a warning led for such cases.

The manometer allows to adjust and control the inlet water pressure.

Wall mounted type, saving space in the laboratories.

Easy and simple operation.



TECHNICAL SPECIFICATIONS

Distilled water capacity	3,5 lt / hr
Cooling water consumption	35 lt / hr
Safety System	Surface thermostat
Power Supply	230 V, 50 Hz.
Power consumption	2500 W
Boiling tank volume	4 lt
Manometer	0-100 mbar
Internal material	Stainless steel
External material	Epoxy-polyester painted aluminum
Overall dimensions (WxDxH)	360x255x545 mm
Net weight	9 Kg.
Gross weight	11 Kg.
Packing dimensions (WxDxH)	475x360x635 mm

Other Nüve Water Distillers

Model	Capacity (lt/hr)
NS 104	4
NS 108	8
NS 112	12

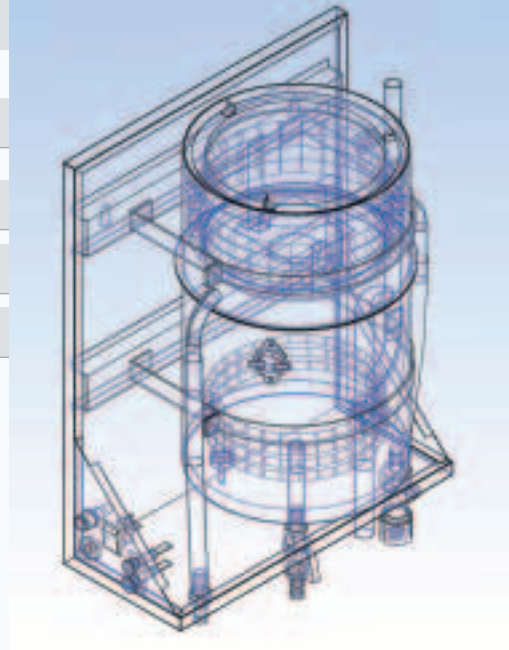

NÜVE SANAYİ MALZEMELERİ İMALAT VE TİCARET A.Ş.

Esenboğa Yolu, 22 km.
Akyurt 06287 ANKARA TURKEY
Tel : (90.312) 399 28 30-31-32 - 399 24 87
Fax : (90.312) 399 21 97
http ://www.nuve.com.tr
e-mail : nuveexp@nuve.com.tr



ISO 9001
ISO 13485

